

DM74LS243 Quadruple Bus Transceiver

General Description

This four data line transceiver is designed for asynchronous two-way communications between data buses. It can be used to drive terminated lines down to 133Ω.

Features

- Two-way asynchronous communication between data buses
- PNP inputs reduce DC loading on bus line
- Hysteresis at data inputs improves noise margin

Connection Diagram

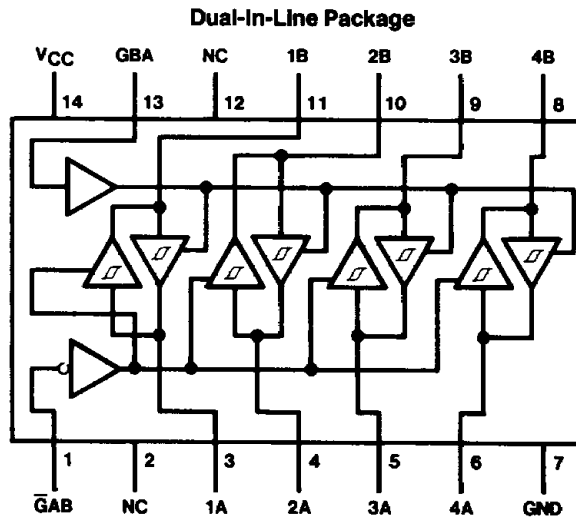

TL/F/6412-1

Order Number DM74LS243WM or DM74LS243N
See NS Package Number M14B or N14A

Function Table

Control Inputs		Data Port Status	
$\bar{G}AB$	GBA	A	B
H	H	O	I
L	H	*	*
H	L	ISOLATED	
L	L	I	O

*Possibly destructive oscillation may occur if the transceivers are enabled in both directions at once.

I = Input, O = Output.

H = High Logic Level, L = Low Logic Level.

Absolute Maximum Ratings (Note)

If Military/Aerospace specified devices are required, please contact the National Semiconductor Sales Office/Distributors for availability and specifications.

Supply Voltage	7V
Input Voltage	
Any G	7V
A or B	5.5V
Operating Free Air Temperature Range	
DM74LS	0°C to +70°C
Storage Temperature Range	-65°C to +150°C

Note: The "Absolute Maximum Ratings" are those values beyond which the safety of the device cannot be guaranteed. The device should not be operated at these limits. The parametric values defined in the "Electrical Characteristics" table are not guaranteed at the absolute maximum ratings. The "Recommended Operating Conditions" table will define the conditions for actual device operation.

Recommended Operating Conditions

Symbol	Parameter	DM74LS243			Units
		Min	Nom	Max	
V _{CC}	Supply Voltage	4.75	5	5.25	V
V _{IH}	High Level Input Voltage	2			V
V _{IL}	Low Level Input Voltage			0.8	V
I _{OH}	High Level Output Current			-15	mA
I _{OL}	Low Level Output Current			24	mA
T _A	Free Air Operating Temperature	0		70	°C

Electrical Characteristics over recommended operating free air temperature range (unless otherwise noted)

Symbol	Parameter	Conditions	Min	Typ (Note 1)	Max	Units	
V _I	Input Clamp Voltage	V _{CC} = Min, I _I = -18 mA			-1.5	V	
HYS	Hysteresis (V _{T+} - V _{T-}) (Data Inputs Only)	V _{CC} = Min	0.2	0.4		V	
V _{OH}	High Level Output Voltage	V _{CC} = Min, V _{IH} = Min V _{IL} = Max, I _{OH} = -1 mA	2.7			V	
		V _{CC} = Min, V _{IH} = Min V _{IL} = Max, I _{OH} = -3 mA	2.4	3.4			
		V _{CC} = Min, V _{IH} = Min V _{IL} = 0.5V, I _{OH} = Max	2				
V _{OL}	Low Level Output Voltage	V _{CC} = Min V _{IL} = Max V _{IH} = Min	I _{OL} = 12 mA		0.4	V	
			I _{OL} = Max		0.5		
I _{OZH}	Off-State Output Current, High Level Voltage Applied	V _{CC} = Max V _{IL} = Max V _{IH} = Min	V _O = 2.7V		40	μA	
I _{OZL}	Off-State Output Current, Low Level Voltage Applied		V _O = 0.4V		-200	μA	
I _I	Input Current at Maximum Input Voltage	V _{CC} = Max	V _I = 5.5V	A or B	0.1	mA	
			V _I = 7V	Any G	0.1	mA	
I _{IH}	High Level Input Current	V _{CC} = Max, V _I = 2.7V			20	μA	
I _{IL}	Low Level Input Current	V _{CC} = Max, V _I = 0.4V			-0.2	mA	
I _{OS}	Short Circuit Output Current	V _{CC} = Max (Note 2)	-40		-225	mA	
I _{CC}	Supply Current	V _{CC} = Max Outputs Open	Outputs High	22	38	mA	
			Outputs Low		29		50
			Outputs Disabled		32		54

Note 1: All typicals are at V_{CC} = 5V, T_A = 25°C.

Note 2: Not more than one output should be shorted at a time, and the duration should not exceed one second.

Switching Characteristics at $V_{CC} = 5V$, $T_A = 25^\circ C$ (See Section 1 for Test Waveforms and Output Load)

Symbol	Parameter	Conditions	Min	Max	Units
t_{PLH}	Propagation Delay Time Low to High Level Output	$C_L = 45 \text{ pF}$ $R_L = 667\Omega$		18	ns
t_{PHL}	Propagation Delay Time High to Low Level Output	$C_L = 45 \text{ pF}$ $R_L = 667\Omega$		18	ns
t_{PZL}	Output Enable Time to Low Level	$C_L = 45 \text{ pF}$ $R_L = 667\Omega$		30	ns
t_{PZH}	Output Enable Time to High Level	$C_L = 45 \text{ pF}$ $R_L = 667\Omega$		23	ns
t_{PLZ}	Output Disable Time from Low Level	$C_L = 5 \text{ pF}$ $R_L = 667\Omega$		25	ns
t_{PHZ}	Output Disable Time from High Level	$C_L = 5 \text{ pF}$ $R_L = 667\Omega$		18	ns
t_{PLH}	Propagation Delay Time Low to High Level Output	$C_L = 150 \text{ pF}$ $R_L = 667\Omega$		21	ns
t_{PHL}	Propagation Delay Time High to Low Level Output	$C_L = 150 \text{ pF}$ $R_L = 667\Omega$		22	ns
t_{PZL}	Output Enable Time to Low Level	$C_L = 150 \text{ pF}$ $R_L = 667\Omega$		33	ns
t_{PZH}	Output Enable Time to High Level	$C_L = 150 \text{ pF}$ $R_L = 667\Omega$		26	ns

This datasheet has been downloaded from:

www.DatasheetCatalog.com

Datasheets for electronic components.

National Semiconductor was acquired by Texas Instruments.

http://www.ti.com/corp/docs/investor_relations/pr_09_23_2011_national_semiconductor.html

This file is the datasheet for the following electronic components:

DM74LS243WM - <http://www.ti.com/product/dm74ls243wm?HQS=TI-null-null-dscatalog-df-pf-null-ww>

DM74LS243N - <http://www.ti.com/product/dm74ls243n?HQS=TI-null-null-dscatalog-df-pf-null-ww>